

**DISCLAIMER:** It is the installer's responsibility to correctly install wheels and related accessories. The information contained in these Guidelines is believed to be reliable, but many factors can lead to installation concerns. The installer must review all available manufacturer information, test fit each wheel before mounting tires to ensure clearance with suspension and braking components, and check all load ratings, offsets and clearance before installation. Neither SEMA, WTC nor their affiliates are responsible for installation errors or the information compiled for these Guidelines.

## MAXIMUM LOAD RATING & MAXIMUM TIRE DIAMETER

The load rating of a wheel, as determined by the wheel manufacturer, must never be exceeded. Manufacturers identify a wheel's maximum load rating and tire diameter - check the back of the wheel or with the wheel manufacturer. If the load rating is not available, THE WHEEL SHOULD NOT BE USED ON THE VEHICLE. Wheel load rating requirements are determined by dividing the vehicle's heaviest gross axle weight rating (G.A.W.R.) by 2. The axle weight rating for most vehicles is shown on the identification label located on the driver's side door jamb, gas tank door, trunk lid or glove compartment.

### WARNING

EXCEEDING THE MAXIMUM LOAD RATING OR MAXIMUM TIRE DIAMETER OF THE WHEEL IS UNSAFE AND COULD CAUSE WHEEL FAILURE, RESULTING IN DAMAGE, SERIOUS INJURY OR DEATH.

INCREASE OR DECREASE IN TIRE DIAMETER ABOVE OR BELOW THE ORIGINAL TIRE DIAMETER MAY AFFECT ROLLOVER AND HANDLING CHARACTERISTICS.

## WHEEL FIT CHECK

Before mounting tires perform a wheel fit check at each wheel mounting location using the following steps:

1. Remove front wheels from vehicle.
2. Clean and inspect all stud threads and mounting surfaces before installation.
3. Remove spring clip retainers, if applicable.
4. Hold the new wheel on the hub and be certain that the wheel mounts flush to the mounting surface of the vehicle. The back side of the wheel must not rest or touch brake drum balancing weights, any brake caliper, suspension component, rivets or obstructions. Removing drum balancing weights to solve wheel fitment problems can result in vehicle vibration not remedied by an off-the-car wheel balancer.

### POSSIBLE OBSTRUCTIONS:

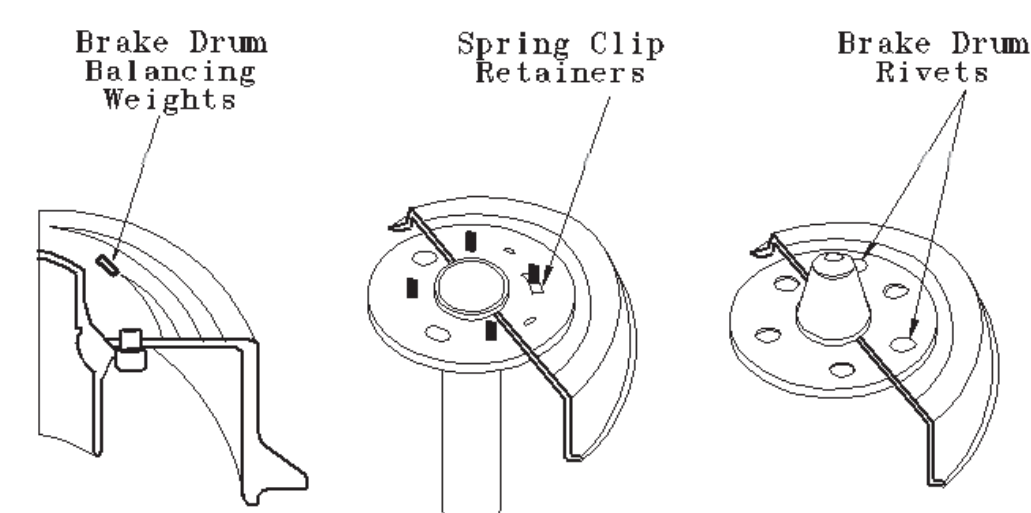

### WARNING

SPRING CLIP RETAINERS ARE OFTEN OVERLOOKED AND MUST BE REMOVED. If clips or other obstructions are not removed, they will not let the wheel sit flush against the mounting surface. This will give you a false torque reading which could cause the fasteners to become loose and result in loss of a wheel. Some vehicle manufacturers do not use spring clip retainers and use nuts that hold the brake assembly together. DO NOT REMOVE THESE NUTS.

5. Install three fasteners finger tight and rotate the wheel to check caliper and suspension clearance and to find bent flanges or axles.
6. Perform the same check for the remaining three wheels on the vehicle, starting in the rear.

### WARNING

Never modify the wheel. Spacers and adapters do not resolve fitment problems. Modification of the wheel or the use of spacers or adapters to resolve clearance or fitment problems could result in an unsafe condition.

**BEFORE INSTALLATION, MAKE SURE YOU HAVE THE CORRECT FASTENERS, WHEEL LOCKS AND CENTER CAPS DESIGNED SPECIFICALLY FOR THE WHEEL AND APPLICATION.**

**CENTER CAPS:** The two basic types of center caps are either inserted from the back of the wheel or attached from the front. For the type inserted from the back, always make sure the flange of the cap matches the wheel's chamfer and is below the mounting surface of the wheel. If the flange of the cap protrudes beyond the mounting surface of the wheel, it will not let the wheel seat properly. If this happens, it will give you a false torque reading and the fasteners may become loose.

### CORRECT!

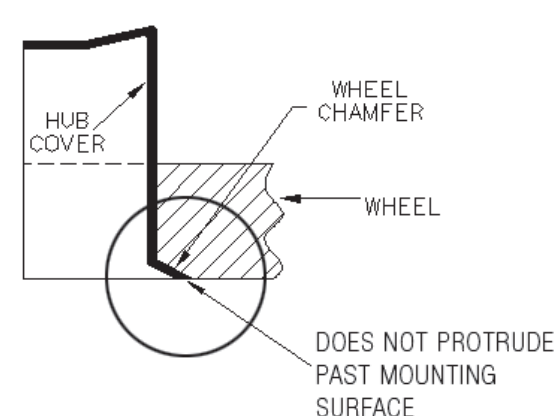

### WRONG!

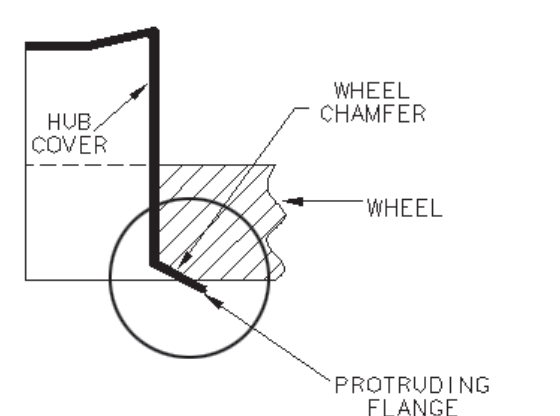

## TIRES

### WARNING

WHEELS AND TIRES ARE MARKED WITH THEIR SIZES. THE WHEEL AND TIRE MUST MATCH BEFORE MOUNTING.

1. Mount all tires according to the FMVSS120 wheel fitment and The Tire and Rim Association book. There are several brands and types of tire mounting equipment available for mounting tires on aftermarket wheels, including rim clamp (euro style) and center-post machines. To avoid scratching or damaging a wheel during mounting/dismounting of tires, make sure the tire machine is properly adjusted and all necessary protective covers are used where metal-to-metal contact is made. Protective eyewear must be used at all times during the mounting/dismounting, installation and servicing of wheels, and related components.
2. The tire manufacturer's requirements and recommendations must be followed.
3. The tire may be labeled with a color dot (painted mark or label, likely in red) that indicates the high spot of the tire's maximum runout or the expected force variation location. This should be aligned with the wheel's low-runout spot, which may be identified with a small notch or color dot. Since labeling approaches vary, check with the wheel manufacturer's instructions for low-spot identification.
4. Use approved tire mounting lubricant on both tire beads and apply to the bead seat area of the wheel if required.
5. Be careful that the bottom bead breaker on center-post changing equipment does not hit the bottom of the wheel as it travels upwards.

### WARNING

6. Place tire and wheel into mounting safety cage and do not exceed 40 pounds of pressure when seating the tire to the bead of the rim. If the tire bead does not seat on the wheel with 40 pounds of pressure, DEFLATE, TURN 180 degrees, RELUBRICATE and check for tire/wheel size mismatch before re-inflation. Do not inflate the mounted tire with the center-post hold-down cone or rim clamps tightened on wheel. Loosen the hold-down cone, but do not completely remove, and release the rim clamps to let the tire expand.

### WARNING

7. Once beads are seated, install the valve core, reconnect the air chuck, set the air regulator and continue to inflate the tire until the manufacturers recommended pressure is reached. Check the bead edges and the valve for leaks, and then install the valve cap. NEVER STAND OVER THE TIRE/WHEEL ASSEMBLY (TRAJECTORY ZONE) DURING INFLATION. ALWAYS STAND TO THE SIDE. DO NOT LEAVE UNATTENDED.

## TIRE CLEARANCE

Wheel manufacturer warranties do not cover tire-to-fender clearance or tire-to-suspension clearances. These clearances must be fit-checked before mounting all the tires. On some "plus" applications rubbing and scuffing may occur. The following procedures must be followed:

1. Mount one tire on a wheel intended for use on the front of vehicle.
2. Install the tire/wheel assembly on the front hub and with the vehicle still on the lift, turn the steering from extreme right to extreme left while checking for any interference with fender well or suspension components.
3. Lower the vehicle and repeat Step 2 with the weight of the vehicle applied.
4. Have someone "bounce" the front of the vehicle and check for tire rub. DO NOT PUT HANDS, FINGERS OR ANY BODY PART BETWEEN THE TIRE AND VEHICLE WHILE CHECKING.
5. Mount one tire on a wheel intended for use on the rear of the vehicle.
6. Install the tire/wheel assembly on the rear hub and check for interference, especially when on the ground and being bounced. Check that wheel balance weights do not contact suspension components and that tires do not contact fenders.

## BALANCING WHEELS

1. Balance tire/wheel assembly according to the balancing machine manufacturer's recommended procedures, following ALL safety precautions.
2. To reduce tire wear, road noise and vibration, all four wheels should be balanced.
3. If you have problems in balancing, review the steps under Wheel Fit Check. Some balancing problems may be remedied by deflating the tire and rotating it approximately 180° on the rim, re-inflating the tire and rebalancing.

## HUB CENTERING RINGS

Prior to installing hub centering rings be sure to check the following:

1. Verify that the inside diameter of the ring is correct by first placing the ring on the vehicle hub and pushing it on the hub until it touches the base of the hub at the point it meets the mounting surface of the vehicle. A good fit is one where the ring is snug against the diameter of the hub and flush against the mounting surface of the vehicle.
2. Verify that the centering ring fits correctly onto the wheel. A good fit is when the ring can be easily pushed by hand onto the back of the wheel and the ring is snug against the walls of the center hole of the wheel. When fully pushed in, the surface of the hub ring must be flush with or just slightly below the mounting surface of the wheel. The hub ring must not protrude beyond the mounting surface of the wheel.
3. To install the centering ring, place the ring into the center hole on the backside of the wheel and mount to the vehicle.

## WHEEL INSTALLATION

1. Clean and inspect all stud threads and mounting surfaces before installation. *Threads must not be lubricated*, and must be free of corrosion, rust, burrs, fractures and damage. Replace if any corrosion, stripping, damage, or fractures are found. Always use new fasteners (lug nuts or lug bolts) when installing new wheels.
2. Be certain the fasteners are correct for the application. They must match the thread diameter, pitch and seat; otherwise the installation will be improper, and may result in damage or a dangerous condition. "Thread diameter" refers to the diameter of the stud measured at the outer edges of the threads. "Thread pitch" for non-metric applications refers to the number of threads per inch; for metric applications, it is the distance between the threads in millimeters. The "seat" means the area on the wheel where the fastener will clamp down.

The basic types of seats are: conical (60° taper "acorn" and "bulge"), mag, and spherical or ball. Shown below is a drawing of each type in its proper application.

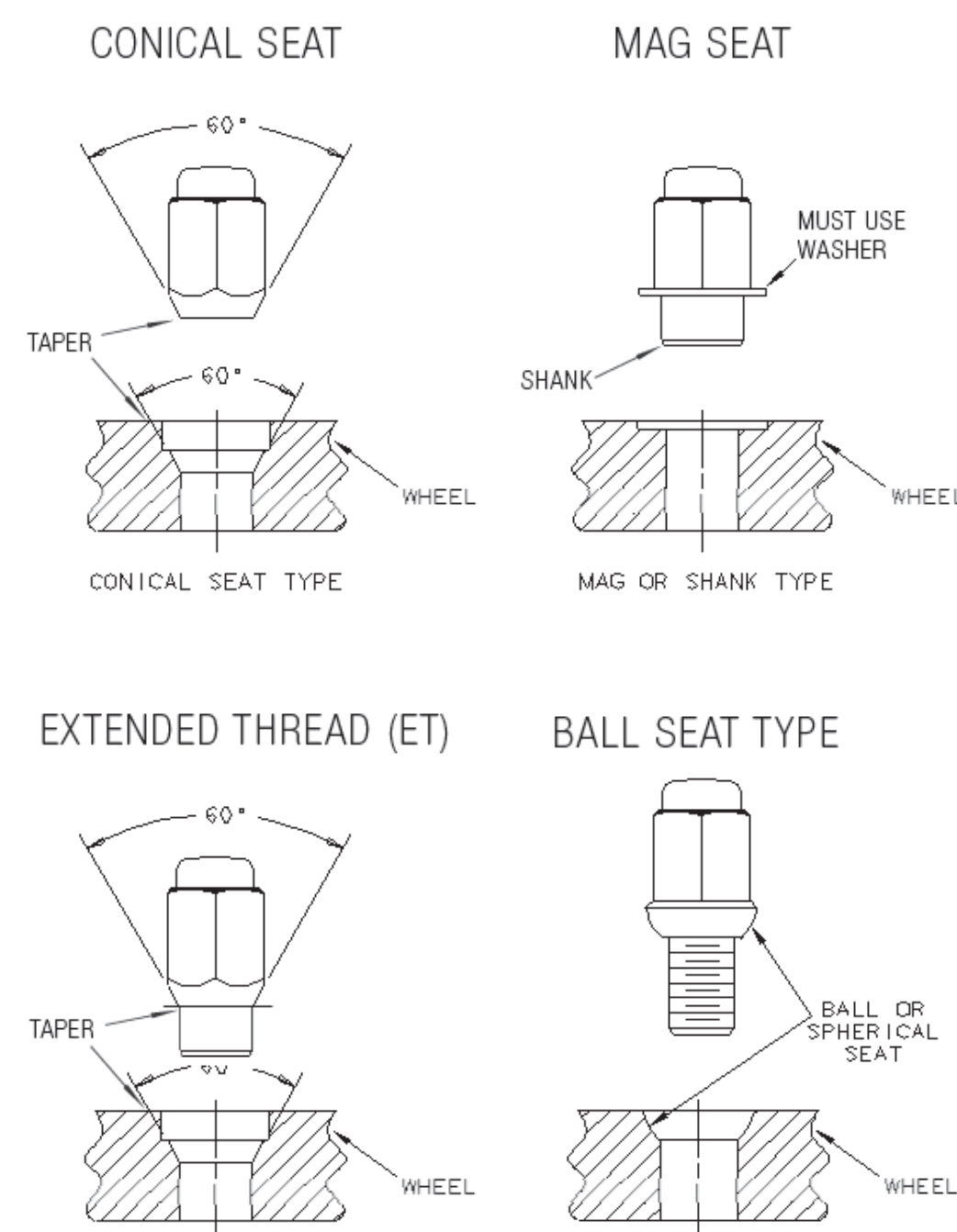

### WARNING

ONLY USE THE TYPE OF FASTENER COMPATIBLE WITH THE TYPE OF SEAT. The different types are not compatible and, if installed incorrectly, the fastener may lose torque, possibly resulting in wheel loss.

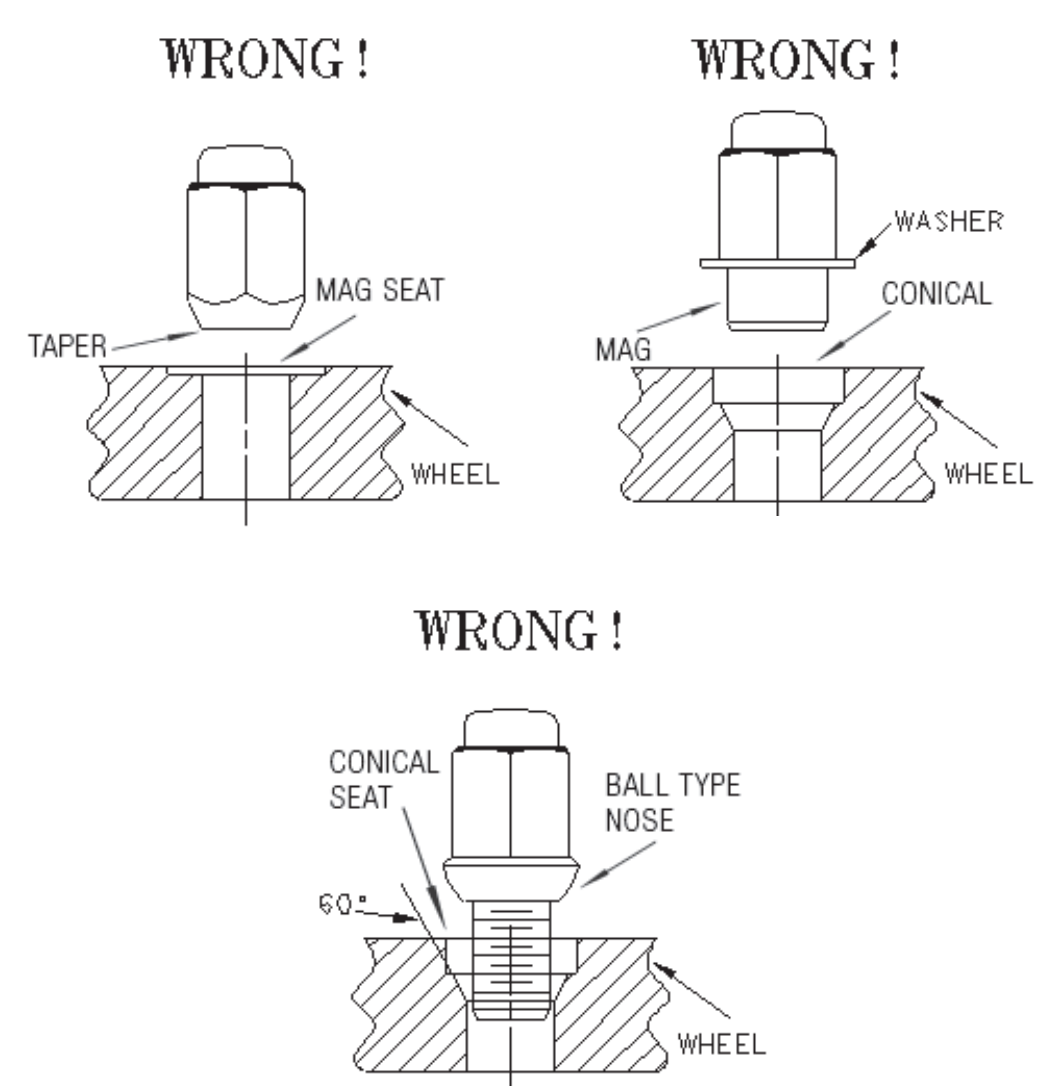

3. Check thread engagement. Every stud or bolt must be long enough to thread a length at least equal to the stud or bolt diameter. For example, a 1/2" thread diameter must thread into the lug nut at least 1/2". Check for this problem on every stud; some may be different lengths. Less than one stud thread diameter engagement is unsafe and will cause loss of torque. IF YOU DO NOT HAVE PROPER THREAD ENGAGEMENT, DO NOT INSTALL WHEELS.

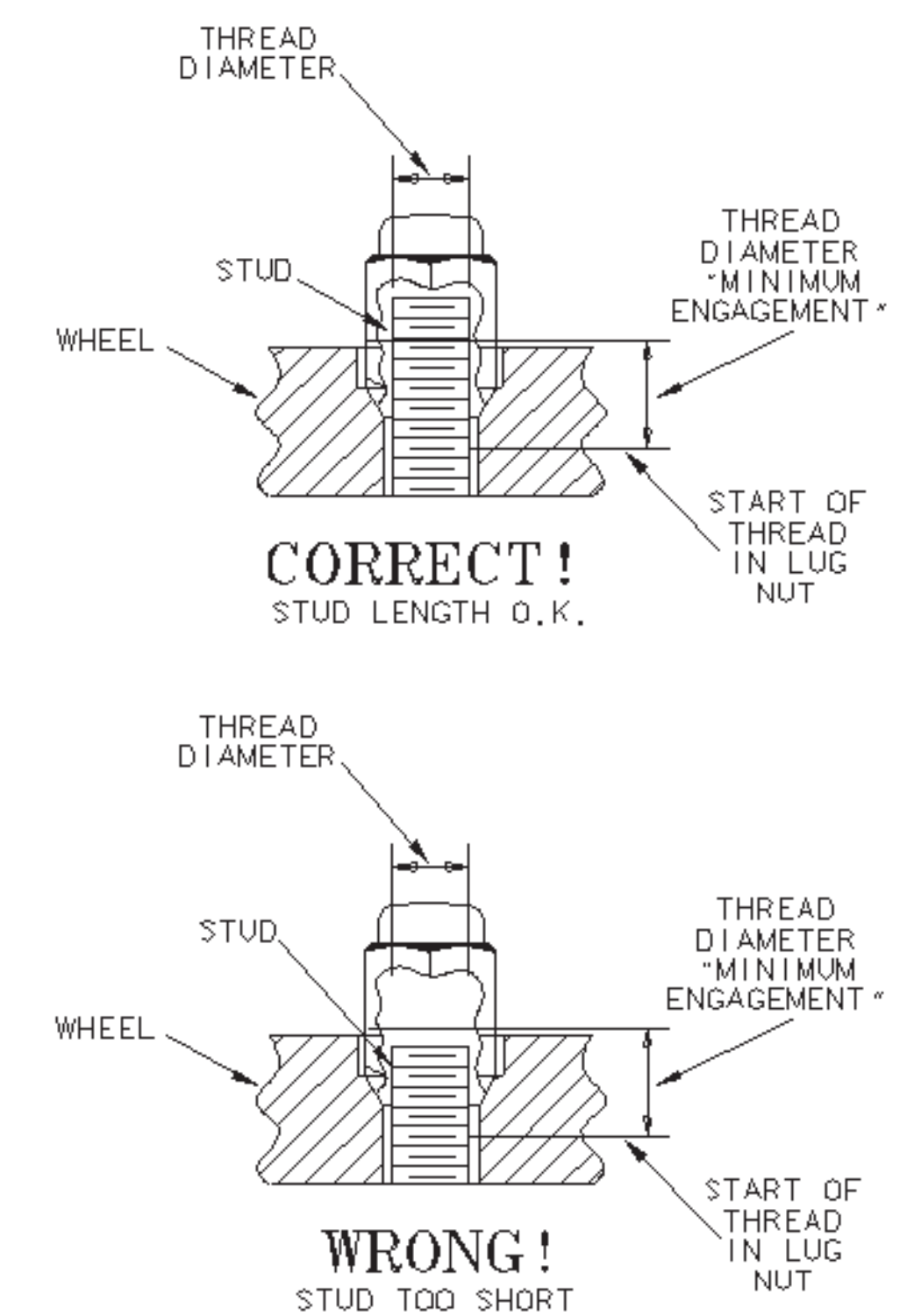

## WARNING

4. Do not allow a lug nut to bottom out on the stud or a shank or lug bolt to bottom out on the mounting surface. This is extremely dangerous and unsafe because the clamping force of the fastener is not being applied to the wheel. Check for these problems on every stud, some may be different lengths. IF YOU FIND A PROBLEM; DO NOT INSTALL WHEELS.

### STUD BOTTOMING OUT IN LUG NUT

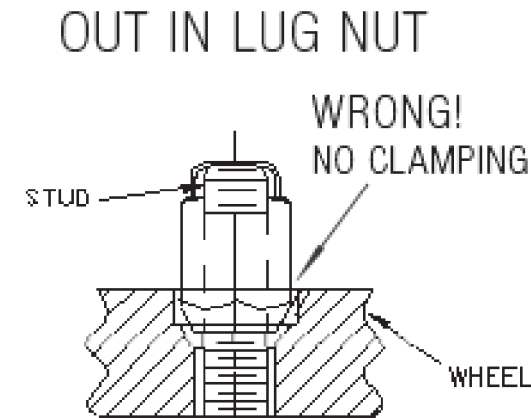

### SHANK OR BOLT CONTACTING MOUNTING SURFACE

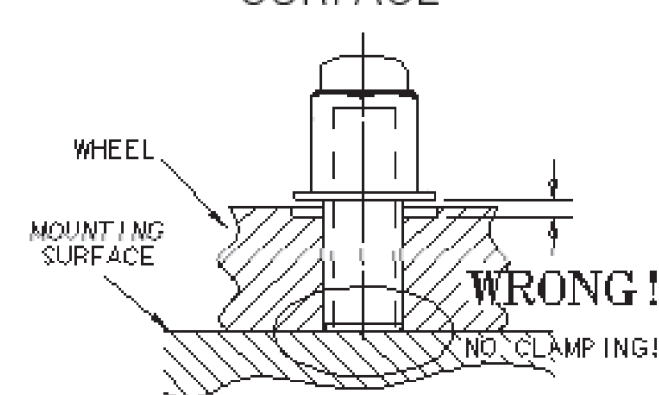

## WARNING

5. Never use fewer fasteners than the vehicle was designed for. If the vehicle has 5 studs or lug bolt holes, then use 5 fasteners.
6. During installation, gravity causes the wheel to rest upon the highest stud. If the wheel is clamped down off-center, it can be dangerous and damaging to your wheels and tires over time. Do not allow the wheel to "hang" on the studs during the initial tightening; make certain the wheel is centered and supported prior to tightening fasteners. Fasteners must be tightened in a star or crisscross pattern to ensure uniform pressure and alignment. Apply torque evenly by repeating the star or crisscross pattern until desired torque is reached. Shown below is the numerical sequence.

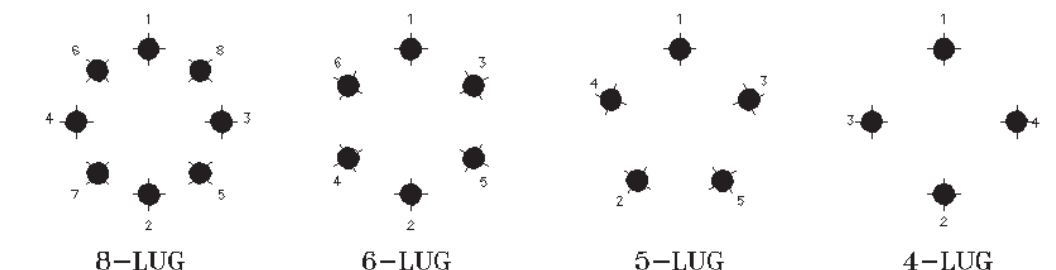

## WARNING

7. A CALIBRATED TORQUE DEVICE MUST BE USED TO ACHIEVE PROPER TORQUE SPECIFICATIONS.
8. Use Original Equipment Manufacturer's torque specification. If it is not specified in the vehicle owner's manual contact the vehicle manufacturer. If the vehicle manufacturer does not provide a specification, check with the aftermarket wheel manufacturer for a specification. If neither the vehicle manufacturer nor the wheel manufacturer gives you the specification, the following may serve as a guideline for passenger cars and light-trucks only:

STUD DIAMETER	TORQUE RANGE (FT./LBS.)
12mm	75 - 85
14mm	85 - 95
7/16"	70 - 80
1/2"	75 - 85
9/16"	105 - 115
5/8"	125 - 135

(Do not under-torque or over-torque fasteners)

9. Check new fasteners against the vehicle wrench making sure they are same size. If the new fasteners have a different hex size than the wrench provided with the vehicle, be sure to have (or advise the customer to have) with the vehicle a wrench matching the new fasteners being installed.
10. If the new fasteners have a different seat than the original equipment, make sure you keep enough of the original fasteners with the spare tire/tire changing equipment so if needed the spare tire can be mounted with the correct fasteners.

## MULTI-PIECE WHEELS

1. Multi-piece wheels require extra care when mounting tires. These wheels may have a special silicone sealant between the rims and the centers. This seal must not be touched with any tire mounting tools. If a tool contacts this area, the seal may be damaged and cause a leak.
2. When the tire valve is close to the seal, use caution in installing and removing the valve to prevent damage to the seal.
3. DO NOT TIGHTEN WHEEL ASSEMBLY BOLTS. They should be torqued at the wheel factory to manufacturer's specifications. If any appear loose, contact the wheel manufacturer for instructions.

## AFTER INSTALLATION

### WARNING

- Be aware of or advise the customer of the following:
1. Fasteners should have a torque check performed within the first 100 miles or 2 to 3 days. A torque check should be performed any time a fastener is removed for any reason.
  2. Write the specified torque requirement on the owner's wheel documents and review the complete instructions.
  3. Keep the wheel documents with the vehicle owner's manual. When the vehicle is sold, both should be given to the new owner.
  4. If wheel locks were installed, keep the key in a secure location and learn how to obtain replacement/additional keys.
  5. Clean tires and wheels (see wheel maintenance information).
  6. Customers should review, initial and sign safety checklist provided on the wheel owner's manual.